

# Data Sheet



Article number: 071581300400050

Description: Cardan drive shaft 0.158.130.001  
S=400 X=50 Bore with keyway

## Measures

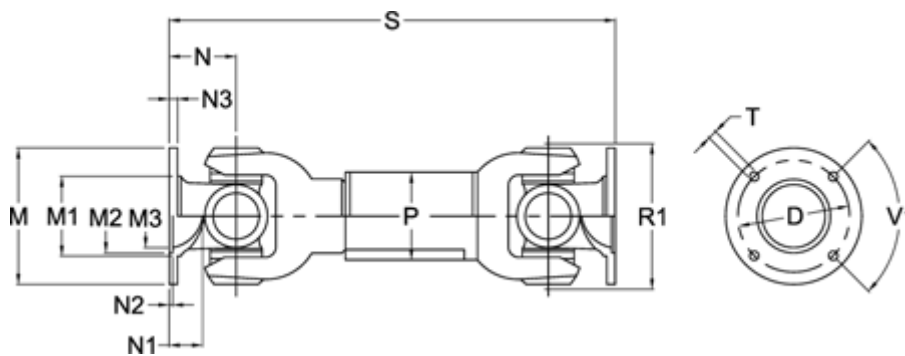

D	= 130 +0,1	N1	= 25	T	= 12 B12
Extension X	= 50	N2	= 3 +0,5	V1 degrees	= 45
Flange diameter M	= 150	N3	= 12		
M1	= 104	Number og Flangeholes	= 8		
M2	= 90	P	= 90x4		
M3	= 82	R1	= 150		
Max. Bending Angle degrees	= 20	S min	= 400		
N	= 75	Spline dim. DIN 5480	= 60x2,5x22		